

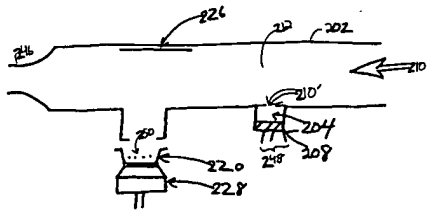

INTERNATIONAL APPLICATION PUBLISHED UNDER THE PATENT COOPERATION TREATY (PCT)

(51) International Patent Classification: A61M 15/00		(11) International Publication Number: WO 99/64095	
(22) International Filing Date: 14 June 1999 (14.06.99)		(43) International Publication Date: 16 December 1999 (16.12.99)	
(71) Applicant: MICRODOSE TECHNOLOGIES, INC. (US/US); 4262 U.S. Route 1, Monmouth Jct., NJ 08852 (US).		(81) Designated States: AE, AL, AM, AT, AU, AZ, BA, BB, BG, BR, BY, CA, CH, CN, CU, CZ, DE, DK, EE, ES, FI, GB, GD, GE, GH, GM, GR, HU, ID, IL, IN, IS, JP, KE, KG, KP, KR, KZ, LC, LK, LR, LS, LT, LU, LV, MD, MG, MK, MN, MW, MX, NO, NZ, PL, PT, RO, RU, SD, SE, SG, SI, SK, SL, TH, TM, TR, TT, UA, UG, UZ, VN, YU, ZA, ZW, AR, IPO patent (GH, GM, KR, LS, MW, SD, SL, SZ, UG, ZW), Eurasian patent (AM, AZ, BY, KG, KZ, MD, RU, TJ, TM), European patent (AT, BE, CH, CY, DE, DK, ES, FI, FR, GB, GR, IE, IT, LU, MC, NL, PT, SE), OAPI patent (BF, BJ, CF, CG, CI, CM, GA, GN, GW, ML, MR, NE, SN, TD, TG).	
(72) Inventors: ABRAMS, Andrew, L.; 26 Imperial Avenue, Westport, CT 06880 (US); GILMASTE, Assad, V.; 7 Ardley Court, Robbinsville, NJ 08861 (US); FLEMING, Scott; 18 Riverview Drive, Irving, NJ 08623 (US).		Published Without international search report and to be republished upon receipt of that report.	
(74) Agent: SOLOWAY, Norman, F.; Hayes, Soloway, Hennessy, Grossman & Hager, 175 Canal Street, Manchester, NH 03101 (US).			

(54) Title: METERING, PACKAGING AND DELIVERY OF PHARMACEUTICALS AND DRUGS



(57) Abstract
A dry powder inhaler comprises a first chamber in which a dry powder may be disaggregated by a vibrator and separated by size, and a second chamber in which the size-separated disaggregated powder may be picked up by an air stream and carried for introduction into a patient. Electronic circuitry (48) is included for controlling dosing. In another embodiment of the invention, a fluid sensor is employed to activate and control various components of an inhalation device. The fluid sensor includes an acoustic element (208), such as a microphone, positioned within said inhalation device to detect fluid within the device and output signals representative of the frequency and/or amplitude of the fluid. These signals control and activate an electrostatic plate (226) and/or a high frequency vibrator (228). In yet another embodiment of the invention, electrostatic photoacoustics is used to package microgram quantities of fine powders such as drugs in discrete capsule and tablet form. An electrostatic "image" (325A) having a given size and charge density is exposed to ionized drug powder to attract a known amount of drug to the image. The resultant drug "image" (326A) is then transferred (330) to an open ended capsule (329), a partially formed tablet (360) or edible wafer (384) or belt (390). The capsule is then sealed, e.g. by capping, or the tablet finished.

FOR THE PURPOSES OF INFORMATION ONLY

Codes used to identify States party to the PCT on the front pages of pamphlets publishing international applications under the PCT.

AL	Albania	ES	Spain	LF	Lesotho	SI	Slovenia
AM	Armenia	FI	Finland	LY	Libyan Arab Jamahiriya	SK	Slovakia
AT	Austria	FR	France	LU	Luxembourg	SN	Senegal
AU	Australia	GA	Gabon	LV	Latvia	SR	Sri Lanka
AZ	Azerbaijan	GB	United Kingdom	MC	Monaco	TD	Chad
BA	Bosnia and Herzegovina	GE	Georgia	MD	Republic of Moldova	TG	Togo
BB	Barbados	GH	Ghana	MG	Madagascar	TJ	Tajikistan
BE	Belgium	GN	Guinea	ML	The Gambia	TM	Turkmenistan
BF	Burkina Faso	GR	Greece	MR	Republic of Mauritania	TR	Turkey
BG	Bulgaria	HU	Hungary	MU	Mauritius	TT	Trinidad and Tobago
BR	Brazil	IE	Ireland	MV	Maldives	UA	Ukraine
BS	Bahamas	IL	Israel	MX	Mexico	UG	Uganda
BT	Bhutan	IS	Iceland	NW	Nauru	US	United States of America
CA	Canada	IT	Italy	PL	Poland	UZ	Uzbekistan
CF	Central African Republic	JP	Japan	PR	Puerto Rico	VN	Viet Nam
CG	Congo	KE	Kenya	RO	Romania	YU	Yugoslavia
CH	Switzerland	KG	Kyrgyzstan	RU	Russian Federation	ZW	Zimbabwe
CI	Cote d'Ivoire	KZ	Kazakhstan	SG	Singapore		
CN	China	LA	Laos				
CO	Colombia	LC	St. Lucia				
CU	Cuba	LI	Liechtenstein				
CV	Cape Verde	LK	Sri Lanka				
CZ	Czech Republic	LR	Liberia				
DE	Germany						
DK	Denmark						
EE	Estonia						

WO 99/64095

PCT/US99/13420

WO 99/64095

PCT/US99/13420

1 Metering, Packaging and Delivery of
 2 Pharmaceuticals and Drugs
 3 The present invention relates generally to the field of metering,
 4 packaging and delivery of pharmaceuticals and drugs. Particular utility for
 5 the present invention is found in the area of facilitating metering and
 6 packaging of dry powder medications and/or inhalation of powdered
 7 medications, although other utilities are contemplated, including other
 8 medication applications.
 9 Certain diseases of the respiratory tract are known to respond to
 10 treatment by the direct application of therapeutic agents. As these agents are
 11 most readily available in dry powdered form, their application is most
 12 conveniently accomplished by inhaling the powdered material through the
 13 nose or mouth. This powdered form results in the better utilization of the
 14 medicament in that the drug is deposited exactly at the site desired and where
 15 its action may be required; hence, very minute doses of the drug are often
 16 equally as efficacious as larger doses administered by other means, with a
 17 consequent marked reduction in the incidence of undesired side effects and
 18 medicament cost. Alternatively, the drug in this form may be used for
 19 treatment of diseases other than those of the respiratory system. When the
 20 drug is deposited on the very large surface areas of the lungs, it may be very
 21 rapidly absorbed into the blood stream; hence, this method of application
 22 may take the place of administration by injection, tablet, or other conventional
 23 means.
 24 It is the opinion of the pharmaceutical industry that the bioavailability
 25 of the drug is optimum when the drug particles delivered to the respiratory
 26 tract are between 1 to 5 microns in size. When the drug particles need to be in
 27 this size range the dry powder delivery system needs to address a number of
 28 issues:
 29 (1) Small size particles develop an electrostatic charge on themselves
 30 during manufacturing and storage. This causes the particles to agglomerate

1 or aggregate, resulting in clusters of particles which have an effective size
 2 greater than 5 microns. The probability of these large clusters making it to the
 3 deep lungs then decreases. This in turn results in a lower percentage of the
 4 packaged drug being available to the patient for absorption.
 5 (2) The amount of active drug that needs to be delivered to the patient
 6 may be of the order of 10s of micrograms. For example, albuterol, in the case
 7 of a drug used in asthma, this is usually 25 to 50 micrograms. Current
 8 manufacturing equipment can effectively deliver aliquots of drugs in
 9 milligram dose range with acceptable accuracy. So the standard practice is to
 10 mix the active drug with a filler or bulking agent such as lactose. This
 11 additive also makes the drug "easy to flow". This filler is also called a carrier
 12 since the drug particles also stick to these particles through electrostatic or
 13 chemical bonds. These carrier particles are very much larger than the drug
 14 particles in size. The ability of the dry powder inhaler to separate drug from
 15 the carrier is an important performance parameter in the effectiveness of the
 16 design.
 17 (3) Active drug particles with sizes greater than 5 microns will be
 18 deposited either in the mouth or throat. This introduces another level of
 19 uncertainty since the bioavailability and absorption of the drug in these
 20 locations is different from the lungs. Dry powder inhalers need to minimize
 21 the drug deposited in these locations to reduce the uncertainty associated
 22 with the bioavailability of the drug.
 23 Prior art dry powder inhalers (DPIs) usually have a means for
 24 introducing the drug (active drug plus carrier) into a high velocity air stream.
 25 The high velocity air-stream is used as the primary mechanism for breaking
 26 up the cluster of micronized particles or separating the drug particles from
 27 the carrier. Several inhalation devices useful for dispensing this powder form
 28 of medicament are known in the prior art. For example, in U.S. Patent Nos.
 29 3,507,277; 3,518,992; 3,635,219; 3,795,244; and 3,807,400, inhalation devices are

1 disclosed having means for piercing of a capsule containing a powdered
 2 medicament, which upon inhalation is drawn out of the pierced capsule and
 3 into the user's mouth. Several of these patents disclose propeller means,
 4 which upon inhalation aid in dispensing the powder out of the capsule, so
 5 that it is not necessary to rely solely on the inhaled air to suction powder from
 6 the capsule. For example, in U.S. Patent No. 2,517,482, a device is disclosed
 7 having a powder containing capsule placed in a lower chamber before
 8 inhalation, where it is pierced by manual depression of a piercing pin by the
 9 user. After piercing, inhalation is begun and the capsule is drawn into an
 10 upper chamber of the device where it moves about in all directions to cause a
 11 dispensing of powder through the pierced holes and into the inhaled air
 12 stream. U.S. Patent No. 3,831,606 discloses an inhalation device having
 13 multiple piercing pins, propeller means, and a self-contained power source
 14 for operating the propeller means via external manual manipulation, so that
 15 upon inhalation the propeller means aids in dispensing the powder into the
 16 stream of inhaled air. See also U.S. Patent No. 5,458,135.

17 These prior art devices present several problems and possess several
 18 disadvantages which are remedied by the inhalation devices of the present
 19 invention. For instance, these prior art devices require that the user exert
 20 considerable effort in inhalation to effect dispensing or withdrawal of powder
 21 from a pierced capsule into the inhaled air stream. With these prior art
 22 devices, suction of powder through the pierced holes in the capsule caused by
 23 inhalation generally does not withdraw all or even most of the powder out of
 24 the capsule, thus causing a waste of the medicament. Also, such prior art
 25 devices result in uncontrolled amounts or clumps of powdered material being
 26 inhaled into the user's mouth, rather than a constant inhalation of controlled
 27 amounts of finely dispersed powder.

28 The above description of the prior art is taken largely from U.S. Pat.
 29 No. 3,948,264 to Wilke et al, who disclose a device for facilitating inhalation of

1 column 3, lines 45-55). Wilke et al further discloses that the electromechanical
 2 vibrator means may be placed at a right angle to the inlet chamber and that
 3 the amplitude and frequency of vibration may be altered to regulate
 4 dispensing characteristics of the inhaler.

5 Thus, as noted above, the vibrator in Wilke et al's disclosed inhaler is
 6 an electromechanical device consisting of a rod driven by a solenoid buzzer.
 7 (This electromechanical means may be a motor driving a cam [Col. 4, Line
 8 40]). A disadvantage of the inhaler implementation as disclosed by Wilke is
 9 the relatively large mechanical movement required of the rod to effectively
 10 vibrate the capsule. The large movement of the rod, usually around 100s of
 11 microns, is necessary due to the elasticity of the capsule walls and inertia of
 12 the drug and capsule.

13 Moreover, solenoid buzzers typically have operating frequencies less
 14 than 5 KHz. This operating frequency tends to be noisy and therefore is not
 15 desirable when incorporated into a dry powder inhaler from a patient's
 16 perspective. A further disadvantage of the electrochemical actuators of Wilke
 17 is the requirement for a high energy source (Wilke et al, Col. 3, line 38), thus
 18 requiring a large battery source or frequent changes of the battery pack for
 19 portable units. Both these features are not desirable from a patient safety and
 20 "ease of use" standpoint.

21 The inhaler of Wilke et al is primarily intended to reduce the amount of
 22 powder left behind in the capsule relative to other inhalers cited in the patent
 23 disclosure. (Wilke et al, Col. 4, lines 59-68, Col. 5, lines 1-48). However, Wilke
 24 et al does not address the need to deaggregate the powder into particle sizes
 25 or groups less than 6 microns in size as is required for effective delivery of the
 26 medication to the lungs; rather Wilke et al, like the prior art inhalers continues
 27 to rely on the air stream velocity to deaggregate the powder ejected into the
 28 air stream, into particle sizes suitable for delivery to the lungs.

1 a powdered medication that includes a body portion having primary and
 2 secondary air inlet channels and an outlet channel. The secondary inlet
 3 channel provides an enclosure for a capsule containing the powdered
 4 medication and the outlet channel is formed as a mouthpiece protruding from
 5 the body. A capsule piercing structure is provided, which upon rotation puts
 6 one or more holes in the capsule so that upon vibration of the capsule by an
 7 electro-mechanical vibrator, the powdered drug may be released from the
 8 capsule. The piercing means disclosed in Wilke et al includes three radially
 9 mounted, spring-biased piercing needles mounted in a trochoidal chamber.
 10 Upon hand rotation of the chamber, simultaneous inward radial motion of the
 11 needles pierces the capsule. Further rotation of the chamber allows the
 12 needles to be retracted by their spring mountings to their original positions to
 13 withdraw the needles from the capsule. The electromechanical vibrator
 14 includes, at its innermost end, a vibrating plunger rod which projects into the
 15 intersection of the inlet channel and the outlet channel. Connected to the
 16 plunger rod is a mechanical solenoid buzzer for energizing the rod to vibrate.
 17 The buzzer is powered by a high energy electric cell and is activated by an
 18 external button switch. According to Wilke et al, upon inhalation through
 19 outlet channel 3 and concurrent pressing of switch 10d to activate the
 20 electromechanical vibrating means 10, air is sucked through inlet channels 4
 21 and 12 and the air stream through the secondary inlet channel 4 raises the
 22 capsule up against the vibrating plunger rod 10a. The capsule is thus vibrated
 23 rapidly with powder being fluidized and dispensed from the pierced holes
 24 therein. (This technique is commonly used in manufacturing for dispensing
 25 powder through a hopper where the hopper is vibrated to fluidize the
 26 powder and move it through the hopper outlet. The pierced holes in the
 27 capsule represent the hopper outlet.) The air stream through inlet channel 4
 28 and 12 aids in withdrawal of powder from the capsule and carries this
 29 powder through the outlet channel 3 to the mouth of the user." (Wilke et al.,

1 Another prior art inhalation device is disclosed in Burns et al U.S.
 2 Patent No. 5,284,133. In this device, a liquid medication is atomized by an
 3 ultrasonic device such as a piezo element (Burns et al, Col. 10, lines 36-51). A
 4 stream of air, usually at a high velocity, or a propellant then carries the
 5 atomized particles to the patient. The energy required to atomize the liquid
 6 medication in the nebulizer is prohibitively high, making this approach for
 7 the delivery of drugs to the lungs only feasible as a desk top unit. The high
 8 voltage requirements to drive the piezo, to produce the necessary mechanical
 9 displacements, also severely effects the weight and size of the device. It is
 10 also not obvious that the nebulizer operating principles can be applied to the
 11 dry powder inhalers for delivery of powder medication to the lungs.

12 The prior art devices therefore have a number of disadvantages which
 13 makes them less than desirable for the delivery of dry powder to the lungs.
 14 Some of these disadvantages are:

- 15 • The performance of the prior art inhalers depends on the flowrate
 16 generated by the user. Lower flowrate does not result in the
 17 powder being totally deaggregated and hence adversely affects the
 18 dose delivered to the patient.
- 19 • Inconsistency in the bioavailability of the drugs from dose-to-dose
 20 because of lack of consistency in the deaggregation process.
- 21 • Large energy requirements for driving the electromechanical based
 22 inhalers which increases the size of the devices making them
 23 unsuitable for portable use.

24 In our prior U.S. Patent No. 5,694,920, issued December 9, 1997, we
 25 provide an inhaler that utilizes vibration to facilitate suspension of powder
 26 into a gas that overcomes the aforesaid and other disadvantages and
 27 drawbacks of the above prior art. More particularly, the inhaler of our
 28 aforesaid patent includes a piezoelectric vibrator for vibrating the powder. A
 29 controller is provided for controlling supply (i.e., amplitude and/or

1 frequency) of actuating electricity to the vibrator so as to cause vibration of
 2 the powder that is adapted to optimally suspend at least a portion of the
 3 powder into the gas. As described in our aforesaid patent, the controller may
 4 include a user-actuable control for permitting the user to select the vibration
 5 frequencies and/or amplitudes for optimally suspending in the gas the type
 6 of powder currently being used in the inhaler. The user-actuable control is
 7 pre-calibrated with the controller to cause the controller to adjust the
 8 frequency and/or amplitude of actuating electricity supplied to the vibrator
 9 to be that necessary for vibrating the type of powder selected by the user-
 10 actuable control in such a way as to optimally suspend at least a portion of the
 11 powder into the gas. The user-actuable control may include selection
 12 gradations in terms of the average size of the powder particles to be
 13 suspended in the gas, and/or in terms of desired vibration frequencies and
 14 amplitudes. Vibration frequency would be adjusted to at least about 12 KHz,
 15 in order to optimally suspend such commonly used powdered medications in
 16 the gas. Of course, vibration frequency and amplitude may be adjusted to
 17 optimize suspension of the powdered medication being used.

18 An electrostatic field that is established across the air stream, whereby
 19 by controlling the strength of the electrostatic field primarily only particle
 20 sizes of interest are introduced into the air stream, while larger size particles
 21 are left behind in the container. This reduces the inconsistency associated
 22 with the bioavailability of the drug because of the large particles being
 23 deposited into the mouth or throat as is common with devices described in
 24 prior art.

25 The present invention provides an improvement over prior art
 26 inhalation devices such as described in our aforesaid U.S. Patent No.
 27 5,694,920. In one embodiment of the invention, the inhaler contains two or
 28 more vibrator means or piezoelectric elements so that different drugs, i.e. of
 29 different particle size, may be delivered from the same inhaler.

1 particular medication. For example, acoustic signals can be used to trigger
 2 the high frequency vibrator and electrostatic plate only when the patient has
 3 achieved optimum (e.g., maximum) inhalation effort, thereby ensuring that
 4 the full (proper) dosage of medicament properly enter the patient's
 5 respiratory system. Alternatively, these signals (breath-activated signals) can
 6 be used to progressively apply increasing power to, or, sequentially
 7 activate/deactivate the various components of the inhalation device to
 8 achieve optimal inhalation dosage.

9 The present invention also relates to the packaging of dry powders and
 10 particularly to the metering and packaging of precise quantities of
 11 pharmaceuticals and drugs for medical uses.

12 The certification of new pharmaceuticals is a lengthy and costly process
 13 involving animal studies followed by chemical trails to establish both efficacy
 14 and safety. Because a pharmaceutical's characteristics may be affected by
 15 changes in manufacturing and/or packaging, the approval process limits the
 16 approval to a particular manufacturing and packaging process.

17 In our earlier U.S. Patent 5,699,649, granted December 23, 1997, we
 18 describe a method and apparatus for packaging microgram quantities of fine
 19 powders such as pharmaceuticals using electrostatic phototechnology
 20 techniques. More particularly, as described in our aforesaid U.S. Patent
 21 5,699,649, the ability of powders to acquire an electrical charge
 22 advantageously is utilized for precisely measuring exact microgram
 23 quantities of the powder, whereupon these exact microgram quantities are
 24 then placed in individual containers, and the containers sealed.

25 Electrostatic charge has been employed to attract a given quantity of
 26 powder to a surface. An example of this is the laser printer or the electrostatic
 27 copy devices where a drum is charged and toner particles are attracted and
 28 held in position by the charge. The charge on the drum is neutralized by the
 29 attracted toner powder, thus limiting the amount of toner in accordance with

1 In yet another embodiment of the invention, the piezoelectric elements
 2 are switched between two or more set frequencies, or frequencies swept so as
 3 to avoid potentially setting up standing waves in the powder.

4 In yet another embodiment of the invention, the inhaler includes
 5 electronic circuitry for recording and/or controlling one or more functions
 6 such as dose counting, patient compliance monitoring, and patient
 7 compliance reminders. Also, the inhaler may be programmed according to a
 8 delivery protocol, i.e. to alter the quantity of drug delivered over time. If
 9 desired, the inhaler also may include an environmental sensor and knockout
 10 control, for example, to deactivate the inhaler in the event it is inadvertently
 11 exposed to too high a temperature, a clock to deactivate the inhaler in the
 12 event its shelf life is exceeded, and/or a security/safety lock-out.

13 Still yet another embodiment of the present invention provides an air
 14 flow sensor for controlling various components of an inhalation device.
 15 Included in the preferred embodiment is an acoustic controller, the acoustic
 16 controller including an acoustic element to sense air flow around the element
 17 and for producing signals representative of a frequency and amplitude of the
 18 air flow, the signals being used to control (e.g., activated, deactivate, apply
 19 incremental voltage, etc.) certain components of the inhalation device.

20 Preferably, acoustic element is a microphone element or pressure
 21 transducer positioned within the air passage of an inhalation device, (e.g., a
 22 dry powder inhaler) that produces signals in response to the inhalation air
 23 flow, these signals are used to control certain components of the inhaler, e.g.,
 24 a high frequency vibrator, an electrostatic plate, timer, counter, etc. Also
 25 preferably, these signals are used to activate/control certain components of
 26 the inhalation device to maximize the inhalation effectiveness to obtain
 27 maximum patient benefit from medicament.

28 Thus, the present invention provides a fully automated inhalation
 29 device, that is breath activated, that permits optimal utilization of the

1 the charge image on the drum. The charge on these printer drums is then
 2 transferred to a sheet of paper or other carrier to give a final image. In our
 3 U.S. Patent 5,699,649, the same electrostatic charge technology is employed
 4 for transferring a predetermined amount of a finely powdered
 5 pharmaceutical or drug to a carrier or an intermediate such as a drum,
 6 carrying a charge of predetermined intensity and area, rotating the charged
 7 drum surface, carrying the predetermined amount of powdered
 8 pharmaceutical or drug on its surface, to a transfer station where the charge is
 9 overcome and the dry powder is transferred to a package which is then
 10 sealed. In lieu of a drum, a belt, or other movable surface is charged to a
 11 given potential in a localized area.

12 When a given amount of a powdered pharmaceutical or drug is to be
 13 packaged, the charge and area of charge can be determined experimentally
 14 for each dose of pharmaceutical or drug and each particle size distribution.
 15 This can be done by controlling either the charged area for a given charge
 16 density or the total electrostatic charge on any individual charged area. These
 17 conditions can be adjusted to provide essentially the exact desired amount of
 18 the particular pharmaceutical or drug to be transferred at the transfer station.

19 In the present invention, the electrostatic charge technology described
 20 in our aforesaid U.S. Patent 5,699,649 is adopted to be used for measuring and
 21 packaging unit doses of a pharmaceutical or drug in a readily ingestible form,
 22 i.e. as a tablet or capsule. The technology thus described permits reproducible
 23 precise measurement and packaging of a pharmaceutical or drug, and which
 24 may be scaled from laboratory to pilot plant to full scale production without
 25 the need for recertification.

26 Still other features and advantages of the present invention may be
 27 seen from the following detailed description, taken in connection with the
 28 attached drawings, wherein like numerals depict like parts, and wherein:

29 Figure 1 is a perspective view of an inhaler of the prior art;

1 Figure 2 is a rear plane view of the inhaler shown in Figure 1;
 2 Figure 3 is a longitudinal cross-sectional schematic view of the inhaler
 3 of Figure 1;
 4 Figure 4 is a functional block diagram of the vibration control system
 5 of one embodiment of Figure 1;
 6 Figure 5 is a functional block diagram of the vibration control system
 7 of another embodiment of the invention;
 8 Figures 6-10 are function block diagrams of the vibration control
 9 system in accordance with still yet other embodiments of the invention; and
 10 Figure 11 is a view, similar to Figure 3 of yet another embodiment of
 11 the invention.
 12 Figure 12 is a cross-sectional view of a typical inhalation device and the
 13 acoustic controller of the present invention;
 14 Figure 13 is an expanded cross-sectional view of Figure 12;
 15 Figure 14 is a functional block diagram of a preferred embodiment of
 16 the acoustic controller of the present invention;
 17 Figure 15 shows a schematic representation of the attraction of
 18 negatively charged powder particles to a support having a positive charge on
 19 the surface thereof;
 20 Figure 16 shows a block diagram of the various steps involved in
 21 practicing the invention;
 22 Figure 17 is a schematic representation of one form of drum type
 23 electrostatic device for transferring given small quantities of powdered drugs
 24 from an electrostatic attraction station, where a given quantity of powdered
 25 drug is attracted to and neutralizes a given charge on the drum, and a
 26 subsequent transfer station where the drug is transferred from the drum to a
 27 package thereof;
 28 Figures 18 and 19 are schematic functional representations of preferred
 29 components employed in the Fig. 17 type of apparatus;

11

1 Secondary air conduit 31 is generally L-shaped and runs longitudinally
 2 from opening 30 in the rear 24 surface of the housing 18 to main passage 26.
 3 One-way flow valve 50 is mounted to the inner surface 33 of the main passage
 4 26 via a conventional spring-biased hinge mechanism (not shown), which is
 5 adapted to cause the valve 50 to completely block air flow 5 through the
 6 conduit 31 to the main passage 26 when the pressure of the air flow F in the
 7 main passage 26 is below a predetermined threshold indicative of inhalation
 8 through the passage 26 by a user.
 9 Powder dispensing chamber 54 is formed in housing 18 for holding a
 10 capsule 34 of powder medication to be inhaled. Housing 18 includes a
 11 moveable panel portion 32 in the rear 24 for permitting the capsule 34 to be
 12 introduced into the chamber 54 and placed on the seating 52 of vibration
 13 means 36 between guiding means 60A, 60B. Preferably, means 36 comprises a
 14 hard plastic or metallic protective shell 37 enclosing a piezoelectric vibrator
 15 90. (Figure 4). Preferably, vibrator 90 is mechanically coupled through the
 16 shell 37 via a disk (not shown) to the drug cartridge 34 so as to permit
 17 maximum vibratory energy to be transmitted from the vibrator 90 through
 18 the shell 37 to the cartridge 34. Guiding means 60A, 60B includes two
 19 surfaces which slant downwardly toward the seating 52 so as to permit easy
 20 introduction and retention of the capsule on the seating 52 in the chamber 51.
 21 Removable panel 32 includes another air inlet 34 for permitting additional air
 22 flow 52 from the chamber 51 through conduit 61 into conduit 31 during
 23 inhalation by the user. Preferably, panel 32 and housing 18 include
 24 conventional mating mounting means (not shown) for permitting the panel 32
 25 to be removably resecurable to the housing by the user between introduction
 26 of fresh (i.e., completely full) capsules and removal of spent (i.e., empty)
 27 capsules.
 28 Inhaler 10 also includes a conventional miniature air stream velocity or
 29 pressure sensor 40 mounted on the inner surface of the conduit 26 so as to

13

1 Figure 20 shows a different system wherein separate carriers, having
 2 micronized drug particles electrostatically attached to their surface, are used
 3 to carry the drug to the charged transfer surface;
 4 Figures 21 and 22 show methods of aerosolizing the powdered drug
 5 and ionizing the drug to give it a specific charge;
 6 Figure 23 shows a graph illustrating the percentage of suspended
 7 particles as a function of time and size, permitting creation of a suspended
 8 particle stream of any given desired size distribution;
 9 Figure 24 shows another embodiment of applying the aerosolized drug
 10 to a drum carrying charge "image";
 11 Figure 25 illustrates an ion projection system for creating the charge
 12 "image" on a dielectric surface;
 13 Figure 26 is a view similar to Fig. 16, and illustrating an alternative
 14 embodiment of the invention;
 15 Figure 27 is a view similar to Fig. 16, and illustrating another
 16 alternative embodiment of the invention;
 17 Figure 28 is a view similar to Fig. 16, and illustrating yet another
 18 alternative embodiment of the invention; and
 19 Figure 29 is a view similar to Fig. 16, and illustrating still yet another
 20 alternative embodiment of the invention.
 21 Figures 1-3 illustrate an embodiment 10 of inhaler made in accordance
 22 with our aforesaid U.S. Patent No. 5,694,920. Inhaler 10 includes a hard
 23 plastic or metal housing 18 having a generally L-shaped longitudinal cross-
 24 section. Housing 18 includes four air flow openings 20, 28, 30, and 32. Inhaler
 25 10 includes a main air flow passage 26 which extends the length of the
 26 housing 18 from the front 22 (at opening 20) to the rear 24 thereof (at opening
 27 28) and has a generally square-shaped transverse cross-section, so as to permit
 28 air flow therethrough (denoted by arrow F in Figure 1).

12

1 sense the speed and/or pressure of the air stream F. Preferably, sensor 40
 2 comprises a conventional spring-loaded flapper-yield switch which generates
 3 electronic signals indicative of the speed and/or pressure of the air stream F
 4 in the conduit 26, and transmits those signals via electrical connection 42 to
 5 electronic control circuitry 48 contained in housing 18 for controlling
 6 actuation of the vibrator means based upon those signals.
 7 Preferably, the control circuitry 48 is embodied as an application
 8 specific integrated circuit chip and/or some other type of very highly
 9 integrated circuit chip. Alternatively, control circuitry 48 may take the form
 10 of a microprocessor, or discrete electrical and electronic components. As will
 11 be described more fully below, the control circuitry 48 determines the
 12 amplitude and frequency of actuating power to be supplied from
 13 conventional power source 46 (e.g., one or more D.C. batteries) to the
 14 piezoelectric vibrator to thereby control vibration of the vibrator. The
 15 actuating power is supplied to the piezoelectric element 90 via electrical
 16 connection 44 between the vibrator and the circuitry 48.
 17 Piezoelectric element 90 is made of a material that has a high-
 18 frequency, and preferably, ultrasonic resonant vibratory frequency (e.g.,
 19 about 15 to 100 MHz), and is caused to vibrate with a particular frequency
 20 and amplitude depending upon the frequency and/or amplitude of excitation
 21 electricity applied to the piezoelectric element 90. Examples of materials that
 22 can be used to comprise the piezoelectric element 90 include quartz and
 23 polycrystalline ceramic materials (e.g., barium titanate and lead zirconate
 24 titanate). Advantageously, by vibrating the piezoelectric element 90 at
 25 ultrasonic frequencies, the noise associated with vibrating the piezoelectric
 26 element 90 at lower (i.e., non-ultrasonic) frequencies can be avoided.
 27 Turning specifically to Figure 4, the various functional components
 28 and operation of the control circuitry 48 will now be described. As will be
 29 understood by those skilled in the art, although the functional components

14

1 shown in Figure 4 are directed to an analog realization of the control circuitry
2 48, the components of Figure 4 could be appropriately modified to realize
3 control circuitry 48 in a digital embodiment without departing from this
4 embodiment 10 of the present invention.

5 Control circuitry 48 preferably includes actuation controller 70 and
6 vibratory feedback control system 72. Actuation controller 70 comprises a
7 conventional switching mechanism for permitting actuating power to be
8 supplied from the power source 46 to the control system 72 depending upon
9 the signals supplied to it from sensor 40 and the state of the power switch 12.
10 In other words, controller 70 permits actuating power to be supplied from the
11 source 46 to the system 72 when the sliding indicator bar 14 of switch 12 is set
12 to the "ON" position in channel track 16 and the inhalation sensor 40 supplies
13 signals to the controller 70 that indicate that the inhalation is occurring
14 through the main passage 26. However, controller 70 does not permit
15 actuating power to flow from the source to the system 72 when either the
16 switch 12 is set to "OFF" or the signals supplied to the controller 70 from the
17 sensor 40 indicate that inhalation is not taking place through the conduit 26.

18 When controller 70 first permits actuating power to be supplied from
19 the source 46 to the feedback control system 72, the system 72 enters an
20 initialization state wherein controllable means for supplying a predetermined
21 frequency and amplitude of actuating electricity 74 is caused to generate
22 control signals for causing conventional pump circuit 80 to generate an initial
23 desired frequency and amplitude of actuating electricity based upon stored
24 values thereof stored in the initialization memory means 82. Preferably,
25 means 74 comprises conventional frequency sweep generator and frequency
26 generator means 76 and 78, respectively. The signals generated by means 74
27 are then supplied to charge pump circuit 80 to cause circuit 80 to supply the
28 piezoelectric element 90 with actuating electricity specified by the signals.

15

1 piezoelectric element 90 and signals the sample and hold feedback controller
2 84 when the power transfer characteristics are at local maxima. The controller
3 84 correlates these local maxima with the frequencies and amplitudes
4 commanded by the generator 74 to be supplied to the piezoelectric element
5 90.

6 After the frequency generator 74 has finished its sweep through the
7 frequencies and amplitudes of power supplied to the piezoelectric element 90,
8 the controller 84 causes the generator 74 to cycle through the frequencies and
9 amplitudes of power that resulted in local maxima, and then determines
10 which of these frequencies and amplitudes results in optimal power transfer
11 characteristics through the piezoelectric element 90.

12 Completing the controller 72 is a clock 500 which is tripped when
13 actuating electricity is first supplied to the piezoelectric element 90. Clock 500
14 includes a counter which prevents a second activation of the piezoelectric
15 element for a preset period of time. Thus, overuse and overdosing by the
16 patient are prevented.

17 In operation of embodiment 10, the drug-containing package 34 is
18 punctured and inserted onto the surface 52 of vibrator 36 in chamber 51 in the
19 manner described previously. The power switch is placed in the "ON"
20 position and the user inhales air through the conduit 26, air flow F is
21 generated through conduit 26. This causes one-way valve 50 to deflect to
22 admit air flow S through opening 30 into conduit 26, and also causes air flow
23 S2 through opening 34 and chamber 51 into conduit 26. The inhalation of air
24 stream F is sensed by sensor 40 and is signaled to actuation controller 70,
25 which causes power to be supplied to the controller 72. The controller 72 then
26 adjusts the amplitude and frequency of actuating power supplied to the
27 piezoelectric element until they are optimized for the best possible de-
28 aggregation and suspension of the powder P from the capsule into the air
29 stream F via air flows S and S2.

17

1 Preferably, the initial frequency and amplitude of actuating electricity
2 supplied to the piezoelectric element 90 is pre-calibrated to cause the
3 piezoelectric element 90 to vibrate at its resonance frequency when no
4 powder cartridge or powder is placed on the means 36. As will be
5 appreciated by those skilled in the art, maximum transfer of vibratory power
6 from the piezoelectric element to the powder in the container 34 takes place
7 when the piezoelectric element vibrates at its resonant frequency. It has been
8 found that this results in maximum de-aggregation and suspension of the
9 powder from the container 34 into the air to be inhaled by the user. However,
10 when the container 36 or powder is placed on the vibrator means 36, the
11 weight and volume of the powder container, and the weight, volume, and
12 particular size of the powder to be suspended by the piezoelectric element can
13 change the vibration characteristics of the piezoelectric element, and cause the
14 piezoelectric element to vibrate at other than its resonant frequency. This can
15 result in reduced vibratory energy transfer to the powder from the
16 piezoelectric element, and thereby, lessen the efficiency of the piezoelectric
17 element in de-aggregating and suspending the powder in the air inhaled by
18 the user.

19 The feedback control system 72 overcomes this problem. In control
20 system 72, after the initial frequency and amplitude of actuating electricity are
21 supplied to the piezoelectric element 90, the frequency generating means 74
22 systematically generates control signals indicative of many different
23 amplitudes and frequencies of electricity for being supplied to the
24 piezoelectric element 90 by the circuit 80. As the generating means 74 "cycles
25 through" the different frequencies and amplitudes, the instantaneous power
26 transfer characteristics of the piezoelectric element 90 for each of these
27 different frequencies and amplitudes are determined by the detector 88,
28 which transmits this information to the peak power detector 86. Peak
29 detector 86 analyzes the instantaneous power transfer characteristics of the

16

1 Figure 5 illustrates another embodiment of the invention. Figure 5 is
2 similar to Figure 4, except the clock 500 is replaced with a counter 502 which
3 counts the number of doses delivered by the device. Counter 502 is connected
4 to a display 504 which displays the number of doses delivered, or, optionally,
5 the number of doses remaining.

6 Figure 6 illustrates yet another embodiment of the invention. The
7 Figure 6 embodiment is similar to the Figure 4 embodiment, except the clock
8 500 is replaced by an internal monitor which contains a record of inhaler use.
9 Completing the Figure 6 embodiment is a hatch 510 through which a
10 physician may access, read and/or download the data from monitor 508,
11 whereby to determine patient compliance.

12 Figure 7 illustrates yet another embodiment of the invention. The
13 Figure 7 embodiment is similar to the Figure 4 embodiment except in the
14 Figure 7 embodiment, clock 500 counts time for the purpose of reminding a
15 patient to use the inhaler. Thus, clock 500 is connected to a tone generator 514.

16 Figure 8 illustrates yet another embodiment of the invention. The
17 Figure 8 embodiment is similar to the Figure 4 embodiment, except that it
18 includes a clock or counter 516 which sends a signal to controller 84 to alter
19 the activation time, i.e. to a shorter or longer period, whereby to alter the
20 quantity of drug delivered, e.g. to increase or decrease dosage over time.
21 Alternatively, clock 516 may be programmed to disable the inhaler once a
22 certain date is passed, i.e. so as to avoid possible use of out-of-date drugs.

23 Figure 9 illustrates yet another embodiment of the invention. Figure 9
24 is similar to Figure 4, except the counter or clock 500 is replaced with a
25 temperature sensor 518. Certain medications are heat sensitive, and may be
26 deactivated, or rendered potentially dangerous if exposed to high
27 temperatures, for example, as might occur if the inhaler is left in an
28 automobile on a sunny day. Temperature monitor 518 will deactivate
29 controller 72 in the event a preset temperature is reached. If desired, monitor

18

1 518 also could include a display warning the patient that a preset temperature
2 has been reached.

3 The Figure 10 embodiment is similar to the Figure 9 embodiment
4 except in the Figure 10 embodiment, the temperature sensor is replaced with
5 a "key" such as, for example, a three button keyboard by which the user's pin
6 code must be entered in order to activate the device. This will prevent, for
7 example, use of the inhaler by someone other than the intended patient, and
8 would prevent, for example, controlled or dangerous drugs from being used
9 by children. For ease of use, key 520 may permit the patient (or druggist) to
10 program a specific pin code for the intended user.

11 Referring to Figure 11, which illustrates yet another embodiment of the
12 invention, in which two piezoelectric vibrators 90A, 90B, are located side-by-
13 side within the inhaler shell. In this embodiment, piezoelectric elements 90
14 are designed to vibrate at different amplitudes and frequencies, i.e. so that, for
15 example, two different drugs advantageously may be dispersed
16 simultaneously from the same inhaler, without compromising performance or
17 either drug. This permits delivery of two drugs which, while active together,
18 may not readily be stored together. For example, an asthma inhaler may be
19 provided containing both a bronchodilator, such as albuterol, and a steroid
20 which may require different peizo settings. The Figure 11 embodiment
21 includes a pre-calibrated controller 112 which includes a first and a second
22 pre-calibrated frequency/amplitude control signal generator 110A, 110B,
23 which supplies control signals to pump circuit A and pump circuit B,
24 respectively. Of course, the pre-calibrated controller 112 may be replaced
25 with a pair of feedback controllers similar to that shown in Figure 4.

26 Referring to Figures 12 and 13, a cross-sectional view of an airflow
27 passage 212 of an inhalation device 202 is depicted. It should be noted at the
28 outset that the airflow passage 212 depicted in Figure 12 is a generalized
29 airflow passage of a typical inhalation device, such as those discussed above.

19

1 the cavity 204 with sufficient amplitude to induce a response from the
2 microphone 208.

3 Referring now to Figure 13, an expanded cross-sectional view of an
4 embodiment of the air flow sensor (described with reference to Figure 12,
5 above) in a dry powder inhaler, such as disclosed in U.S. Patent 5,694,920.
6 Depicted in Figure 13 are the components of a typically dry powder inhaler
7 202. A mouthpiece 246 is provided for a user (i.e., patient) to inhale on the
8 device 202. A high-frequency vibratory mechanism 228 (e.g., piezoelectric
9 element, ultrasonic acoustic transducer, or other electro/mechanical vibratory
10 mechanism, etc.) is provided to vibrate a container 220 (e.g., blister capsule) of
11 dry powdered medicament 250 to suspend particles of the medicament into
12 the air passage 212. To further aid the suspension of particles, an electrostatic
13 potential plate 226 can be provided to draw particles of a certain charge (i.e., a
14 charge opposite to that of the electrostatic plate 226) into the air stream 210.
15 In this embodiment, a portion 210' of the air 210 drawn into the air passage
16 212 is induced into the cavity 204, to be detected by the microphone element
17 208. Upon detection of airflow, the microphone element produces output
18 signals 248 proportional in amplitude and frequency of the air flow rate
19 within the air passage 212. The output signals 248 are used to control either
20 the high-frequency vibrator 228 and/or the electrostatic plate 226, or other
21 components of the inhaler, as described below.

22 Figure 14 is a block diagram representation of the acoustic control
23 system of the present invention for a dry powder inhaler. As described above,
24 the microphone element 208 produces signals 248 in response to detected
25 airflow 210'. These signals are processed by an amplitude/frequency
26 processor 230 to condition the signals 248 and to determine the amplitude
27 and/or frequency of the output signals 248. The amplitude/frequency
28 processor produces output signals 248' to control the high-frequency vibrator
29 and/or electrostatic plate. To that end, output signals 248' are input into a

21

1 However, the present invention is intended to be adapted to any inhalation
2 device, regardless of the particular geometry of the airflow passage. At its
3 most basic level, the present invention operates by providing an air flow
4 sensor 208 to detect air flow turbulence around the sensor 208 (i.e., inspiratory
5 air flow rate of a user of the inhaler) and to control various components of the
6 inhalation device 202, as a function of the amplitude and/or frequency of the
7 detected airflow turbulence, as described below.

8 As shown in Figure 12, air 110 (or other fluid) enters the airflow
9 passageway 212, typically by the respiratory activity of a patient inhaling on
10 the device 202. As air 210 flows through the passage 212, a portion thereof
11 flows through the opening 206 in the passage 202 into a cavity 204. Placed
12 within the cavity 204 is an air flow sensing device 208. Preferably, the air flow
13 sensing device 208 is an acoustic sensing device, e.g. a microphone. Also
14 preferably, microphone 208 is adapted to produce appropriate signals 248 in
15 response to the airflow detected within the cavity 204. The amplitude and
16 frequency of the airflow within the cavity 204 is a function of the airflow rate
17 210 within the air passage 212 of the device 202. Thus, output signals 248
18 from the microphone 208 will vary in both frequency and amplitude as a
19 function of air flow rate within the cavity (which is a function of flow rate
20 within the passage 212), and thus, can be used to control various components
21 of the inhaler 202 as a function of frequency and/or amplitude, as described
22 below. Those skilled in the art will appreciate that the shape of the cavity 204
23 and the size of the opening 206 are chosen in accordance the particular
24 geometry of the air passage 212, the air flow rate 210 through the passage 212,
25 and/or the frequency response and/or sensitivity of the microphone 208; and
26 all such variations are within the scope of the present invention. Preferably,
27 as noted above, the shape of the cavity 204 and the size of the opening 206 are
28 chosen to permit at least a portion of the air within the passage 202 to enter

20

1 comparator circuit 240 and/or 232 and compared with a reference threshold
2 signal 242 and/or 234, respectively.

3 It should be understood that signals 248 and 248' are indicative of the
4 airflow rate 210, described above. The present invention is intended to be
5 controllable as a function of frequency and/or amplitude of signals 248, thus,
6 amplitude/frequency processor can be adapted to condition the signals 248 in
7 terms of amplitude or frequency are both. High frequency vibrator threshold
8 242 produces a signal 252 which represents the minimum voltage and/or
9 frequency required to activate the high frequency vibrator controller 244
10 (which, in turn, activates the high frequency vibrator 226). Comparator 240
11 compares signal 252 with signal 248' and if the signals have equal amplitude
12 and/or frequency (within some predetermined error margin), comparator
13 activates the high frequency vibrator controller 244, which activates and
14 directly controls the high frequency vibrator 226. Similarly, electrostatic plate
15 deflector controller 236 is activated by an equal match of signals 248' and 254
16 by the comparator 232. Electrostatic plate detector threshold 234 produces
17 signal 254 which represents the minimum voltage and/or frequency required
18 to activate the electrostatic plate 226.

19 Inspiratory capacity processor 238 is provided to compute the peak
20 inspiratory flow 210 (represented by signals 248 and 248') of the patient.
21 Although not shown in the drawings, this information can be used to adjust
22 the threshold signals of the high frequency vibrator threshold 242 and/or
23 electrostatic plate detector threshold 234. Of course, to accomplish this, the
24 high frequency vibrator threshold 242 and/or electrostatic plate detector
25 threshold 234 must be programmable, as is known in the art. In this way, the
26 microphone 208 can be programmed to trigger the various components of the
27 inhaler to adjust for varying inspiration flow rates from patient-to-patient or
28 individually. Thus, for example, the inspirator control scheme of the present
29 invention can be self-adjusting to account for a patient's decrease in

22

1 inspiratory flow rate caused by, for example, decreased lung capacity.
 2 Alternatively, the processor 236 can be modified to sequentially turn on the
 3 various components herein described (e.g., vibrator, electrostatic plate, etc.) at
 4 optimal inhalation times (e.g., peak inhalation effort). Thus, for example, the
 5 processor 238 can be modified to activate the vibrator at a time just prior to
 6 the user's peak inhalation effort, then to activate the electrostatic plate
 7 subsequently, thereby inducing the medicament into the airstream at a time
 8 that produces optimal respiratory absorption of the medicament. Moreover,
 9 processor 236 can be adapted with appropriate memory to track a patient's
 10 inspiratory flow rate which can be used to adjust the powdered medicament
 11 250 to achieve maximum medication benefit.

12 Many modifications, alternatives and equivalents are possible. For
 13 example, Processor 230, threshold signal generators 234 and 242, comparators
 14 242 and 232 and can be any known digital (e.g., microprocessor) or analog
 15 circuitry and/or associated software to accomplish the functionality described
 16 herein. Although the various components described in Figure 14 have been
 17 described in a modular fashion, those skilled in the art will recognize that
 18 each of these components can be discrete off-the-shelf or custom components,
 19 or can be included in a single, unified system.

20 The present can be modified by permitting the microphone signals 248
 21 and 248' to directly control activation of the high frequency vibrator 228
 22 and/or electrostatic plate 226, thereby bypassing the comparators 240 and/or
 23 232. In this way, microphone 208 can be adapted to activate these
 24 components in a binary fashion that is not dependent upon flow rate. Also, it
 25 will be understood to those skilled in the art that the thresholding circuits 242
 26 and 234, the amplitude/frequency processor 230 and the inspiratory capacitor
 27 processor 238 can be adapted to permit user (patient) control and user-
 28 definable presets (i.e., minimum flow rate for activation, etc).

1 a counter, or the like, that simply counts the amount of times that the device
 2 has been used.

3 Although the present invention has been directed to an acoustic control
 4 scheme for a dry powder inhaler 202, the present invention is not so limited.
 5 On the contrary, the present invention is intended to be adapted for any
 6 inhalation device that would require a control mechanism (such as described
 7 herein) based breath (inhalation) detection. For example, an anesthetic device
 8 could be modified with the breath sensor and controller as provided herein to
 9 monitor and control the amount of anesthetic a patient receives.
 10 Additionally, the acoustic sensing element can be used to measure peak
 11 inspiratory and/or expiratory flow of a particular patient, and record this
 12 information for downloading and analysis.

13 Referring to Figure 15 there is illustrated a chamber 314 containing
 14 aerosolized dry powder particles of a pharmaceutical or drug 310. These
 15 particles 310 are suspended in air and carry a charge, for example a negative
 16 charge. Also in the chamber is a support surface 312 having a charge opposite
 17 to that on the particles. The support surface 312 will attract a number of
 18 charged particles 310 sufficient to neutralize the charge on the surface of the
 19 support 312. This support surface is one that can hold a discrete electrical
 20 charge on its surface, such as insulating material, e.g. plastic or a
 21 semiconductor material, such as selenium, used in the photocopy industry.

22 The actual amount of pharmaceutical or drug powder transferred to
 23 the carrier sheet is a function of the mass-to-charge ratio of the powdered
 24 particles. If one assumes surface charge saturation, the amount of charge
 25 carried by the particles is directly related to the surface area. For spheroidal
 26 particles, the charge varies as the square of the radius and the mass varies as
 27 the cube. Thus, the amount of charged particles picked up by a given portion
 28 of the surface of the charge carrier will be a function the total charge on the
 29 carrier. Thus, with a given surface charge density on the carrier, the amount

1 In addition, comparators 240 and 232 can be adapted to permit
 2 generation of activation signals based differing signal strengths and/or
 3 frequency. Thus, for example, the high frequency vibrator can be adapted to
 4 activate only when a signal frequency of 1Khz is achieved, while the
 5 electrostatic plate will only activate when a signal strength of 35mV. is
 6 obtained.

7 Other modifications are also possible. For example, the microphone
 8 208 can be positioned directly on the inner wall of the airflow passage 212 of
 9 the device 202, instead of within the cavity 204. Also, as shown in Figure 12, a
 10 turbulence generator 214 can be provided to generator air turbulence within
 11 the air passage 212. This modification, for example, can be used in an
 12 inhalation device that would otherwise not permit a portion 210' of the air 210
 13 to enter the cavity 204. In addition, instead of a microphone 208, the acoustic
 14 element can be any known fluid pressure transducer (e.g., air pressure
 15 transducer) that will output appropriate signals as a function of fluid pressure
 16 (amplitude) and/or frequency. Accordingly, the present invention can be
 17 appropriately modified to operate in any fluid medium (other than air), to
 18 provide automatic acoustic control.

19 Still other modifications are possible. For example, although not
 20 shown in the drawings, the present invention can be provided with a timer
 21 that is controlled by signals 248'. The timer can be appropriately modified to
 22 control a schedule of when the device may be activated, to avoid, for example,
 23 an overdose. Thus, for example, the timer may be modified to only permit
 24 activation of the components of the device at certain times of the day.
 25 Moreover, the timer may be appropriately modified to permit downloading
 26 of data related to usage (e.g., time of day used, dosage of medicament,
 27 inhalation effort, etc.). This data can be particularly relevant for clinical trials
 28 where it is important to track the recommended dosage and times of
 29 medication. Of course, the previous description could be accomplished with,

1 of pharmaceutical or drug powder picked up is directly proportional to the
 2 charged area. Thus, for doubling the amount of pharmaceutical or drug
 3 powder to be picked up, and thus the dose amount, the area on which charge
 4 is placed can be doubled. This can be used as a basic method to control the
 5 amount of powder to be picked by the carrier. Thus, for any particular
 6 powder or particle size distribution of powder, the exact area and amount of
 7 charge needed can be experimentally determined.

8 Referring now to Figure 16, there is a schematic flow diagram of the
 9 various items of equipment needed to perform in the total process from
 10 powder supply to packaged pharmaceutical or drug, i.e. in capsule form,
 11 containing a specified amount of pharmaceutical or drug powder in the
 12 package. At 316 is indicated the pharmaceutical or drug powder supply
 13 which is fed into a device 318 for creating an aerosol of the powder. Next the
 14 powder particles are ionized at 320. As will be indicated later, a number of
 15 these steps and pieces of equipment can be combined. At 324 is indicated a
 16 carrier surface capable of maintaining a space charge on its surface. This can
 17 be a plastic belt, for example, or a selenium drum of the type used in Xerox™
 18 photocopiers. This carrier surface 324 is passed through a charging station
 19 325 where a predetermined electrostatic charge 325A (an electrostatic
 20 "image") is created on a predetermined area of the transfer surface. This
 21 charged surface 325A then passes through a step 326 wherein powder is
 22 deposited on the carrier surface in a sufficient amount 326A to neutralize the
 23 charge carried by the carrier surface. Thereafter, the carrier surface, carrying
 24 the predetermined amount 326A of powder on its surface, is passed to a
 25 powder discharging device 330 which discharges the powder 326A from the
 26 surface 324 into the open end of a capsule 329, which capsule is carried on a
 27 conveyor belt 328. A carrier 324 and conveyor belt 328 are indexed and
 28 synchronized in a predetermined manner so that the electrostatic "image"
 29 aligns directly over the open end of capsule 329 and powder discharging

1 device 330 during the discharge sequence. At that time powder discharging
2 device 330 is activated whereupon the predetermined amount 326A of
3 powder is released from surface 325A, and falls into capsule 329. The capsule
4 329 containing its charge of powder 326A, then passes through a capsule
5 sealing step 332 wherein the capsule is capped.

6 As mentioned previously in discussing Figure 15, the carrier surface
7 with the electrostatic charge carries a known amount of charge on its surface
8 and the polarity of this charge is opposite to that of the powder particles
9 suspended in the chamber. The charged particles migrate to the charged
10 surface because of the attraction by the opposite nature of the charges. This
11 migration of the particles continues until the charge on the carrier surface is
12 neutralized.

13 The actual amount of powder mass transferred to the carrier surface is
14 a function of the mass-to-charge ratio of the charged particles. Although it is
15 difficult to achieve a linear relationship between the mass and the actual
16 charge, it is possible to establish a fixed relationship between the surface area
17 of the powder particles and the charge the powder particle is carrying at
18 charge saturation. However, the surface area of a mixed group of powder
19 particles of different sizes and shapes can be extremely difficult to calculate
20 mathematically, particularly when the shapes are irregular, (e.g. non-
21 spherical, microcrystalline, etc.) As mentioned earlier, the simplest method
22 of determining the amount and area of charge to attract a given weight of
23 particles is to estimate the correct area and charge and then apply the
24 estimated charge to the estimated area on the carrier surface 324 and expose
25 this selectively charged area to a mass of powder which has been ionized in
26 the ionizing step. The amount of powder deposited can then be readily
27 measured at the discharge step. Thereafter, either the size of the charged area
28 or the amount of charge applied to the area at the charging station 325 can be
29 adjusted upwardly or downwardly to provide the correct amount of charge.

1 image 325A should be higher than the positive charge on the surface of the
2 individual carriers 360.

3 Figures 21 and 22 show additional details of means for both handling
4 drugs and providing aerosolization and ionization to provide a suspended
5 stream of fine drug powders having a predetermined size and charge. In
6 Figures 21 and 22, elements 316A, 318A and 320A and 316B, 318B and 320B
7 correspond to the equivalent elements in Figures 16, 17 and 18.

8 Since repeatability is important for drug metering it is necessary to
9 effectively address the issue of charge-to-mass variation with particle size.
10 One method of over-coming this problem is to control the particle size
11 distribution in the drug powder. Figure 22 shows one implementation to
12 achieve this control of particle size. The voltage on the electrostatic deflector
13 is adjusted to control the particle sizes to be suspended in the holding
14 chamber for delivery to the ionization chamber. Once the desired particle
15 sizes are suspended they are drawn into the ionization chamber to ensure
16 surface charge saturation on the particles. This will give a known charge to
17 the mass ratio.

18 Figure 21 shows an alternative means for controlling the size
19 distribution. A high velocity air stream is used to deaggregate the powder.
20 The deaggregated powder is then contained in holding chamber 318A. The
21 purpose of the holding chamber is to allow the larger size particles to settle,
22 thereby producing a favorable particle size distribution. The particle size
23 distribution is a function of the holding time as shown in Fig. 23. The
24 suspended particles are then ionized and exposed to the charge image as
25 shown at 326 in Figure 17.

26 Fig. 23 shows the percentage of particles sizes suspended in a holding
27 chamber as a function of time. Such a chamber may be provided with a slow
28 upward flowing air current to maintain the aerosol suspension. As can be
29 seen, the percentage of suspended particles is very largely determined by

1 both in area and charge intensity, for picking up a desired weight of
2 oppositely charged powder.

3 Referring now to Figures 17, 18 and 19, one preferred apparatus for
4 accomplishing the invention is illustrated schematically in Figure 17, with
5 details of the components thereof being shown in Figures 18 and 19. The
6 charge carrying surface is illustrated as a photo sensitive drum 324A which
7 rotates between the charge "image" exposure 325 which creates a charge
8 "image" 325A on the surface of the drum 324A. (see Figure 18) This "image"
9 exposure can be a light source e.g., a laser beam (or other controllable photon
10 source), which is capable of creating an electrostatic "image" 325A on the
11 surface of the drum of a desired size and charge density. The charge "image"
12 325A is then rotated to the image development station containing an ionized
13 cloud of drug powder which is attracted to the charge "image" 325 to
14 neutralize charge in the "image", thus, forming a powder "image" 326A
15 containing a predetermined amount of powder. (see Figures 18 and 19) This
16 powder "image" 326A is rotated to a drug transfer station 330 where it is
17 released into the open ended capsule 329 carried on belt 328. This transfer to
18 the capsules 329 is accomplished, in one preferred embodiment, by the use of
19 high voltage plate 356 (see Figure 19) which overcomes the attraction of the
20 charged "image" 325A on the surface of the drum, thus releasing the powder
21 "image" 326A into the capsule 329. The pocket containing the predetermined
22 quantity of drug is then passed through the capsule capping step 332.

23 Figure 20 shows another embodiment of the invention wherein the
24 micronized drug particles 310 are carried on the surface of discrete carriers
25 360 which can be, for example, small plastic beads, for example. When these
26 plastic beads are contacted with an image 325A, the micronized particles 310
27 are transferred to the charge "image" 325A on the surface of the drum 324A
28 from the discrete carriers 360. To accomplish this, the positive charge on the

1 particle size. Through experiment one can select a time slot that will give the
2 desired particle size distribution for any particle drug dosage. Additionally,
3 or in place of settling time, one or more filters can be used for obtaining a
4 given particle size range.

5 Fig. 24 is similar to Figure 18 except that the Image Development
6 Station 326A in this figure is replaced with a stationary electrode 326B and an
7 air passageway 350 for carrying the aerosolized powder. The rotating drum
8 has a dielectric or photoreceptor surface 324 on to which is deposited the
9 latent image. As an example the aerosolization chamber would be similar to
10 that shown in Figure 21. The metering chamber in Figure 21 is then the air-
11 passageway 325 between the dielectric surface 324 and the stationary
12 electrode 326B. The undeposited powder then exits at the right side of this
13 air-passageway to be collected for later use or recirculated back into the
14 aerosolization chamber.

15 Figure 25 above shows an ion projection print head where an ion beam
16 is used to produce a charge "image" on a dielectric surface. The corona wire
17 352 has a high voltage applied to it which causes the air to breakdown and
18 produces the ions 352A necessary for the operation of the ion projection
19 printers. The remainder of the ion projection print head includes the usual
20 control electrode 354, screen electrode 356 and insulator 358. The relative
21 potential that is applied to the control and screen electrodes then regulates the
22 amount of ions 325C that will be metered and deposited on to the dielectric
23 surface 324 these ions being deposited on the surface to form the latent image
24 325A. Both the intensity and size of the ion beam can be adjusted as will be
25 apparent to one of ordinary skill in the art. The advantage of this system is
26 that it does not require a photosensitive surface and can therefore be rugged
27 making it suitable for the manufacturing environment.

28 The invention is susceptible to modification. For example, the
29 invention advantageously may be employed to form tablets each containing a

1 precise amount of pharmaceutical or drug. Figure 26 is similar to Figure 16.
 2 However, in the Figure 26 embodiment, tablet binder material 360 is
 3 deposited in wells 362 of belt 364 at a first depositing station 366. The belt 364
 4 carrying the partially filled wells 362 is then passed into powder discharging
 5 device 330, where the belt is indexed, as before, in coordination with carrier
 6 surface 324. The predetermined amount 326A of powder is then discharged
 7 from surface 324 into well 362, whereupon the belt is then moved to a well
 8 filling station 368 where the wells 362 are filled. Well filling station 368 may
 9 include a doctor blade (not shown) or the like, for topping the wells 362.
 10 Thereafter the filled wells pass through a tablet hardening station 370 wherein
 11 the tablets are formed into unitary masses in known manner.
 12 Figure 27 illustrates another alternative embodiment of the invention,
 13 in which the surface of the drum 324 bearing the charged "image" 325A is
 14 passed through a powder bath or fluidized bed 380 containing the powder
 15 particles. As before, the powder particles will stick only to the charged area
 16 on the surface of the drum.
 17 Referring to Figure 28, in yet another embodiment of the invention, a
 18 transport belt 382 carries a plurality of spaced edible wafers 384 or the like
 19 upon which the predetermined amount of powder 386 may then be
 20 discharged onto the individual wafers.
 21 Referring to Figure 29, in yet another embodiment of the invention,
 22 transport belt 382 carries tape or sheet 388 formed of an edible substrate such
 23 as starch. The powder particles 390 are deposited uniformly on the sheet 388,
 24 which is then stripped from the belt 382, and cut into specific sizes to
 25 determine the dose.
 26 As can be seen from the foregoing description, the present invention
 27 permits metering and packaging of dry powder pharmaceuticals and drugs,
 28 in a highly precise, reproducible manner. Moreover, the invention readily
 29 may be scaled from laboratory, i.e. desk top size, to pilot plant to full scale

1 production capacity by simply changing size and/or handling speed. Since all
 2 units operate according to identical processes, the drug used for clinical trials
 3 would have the same manufacturing process as in full scale production.
 4 Thus, production certification may be simplified.
 5 Another advantage of the present invention is that the system may be
 6 employed to meter and deposit different drugs and/or different dosages by
 7 simply changing the "image". Alternatively, dosages may be changed, e.g.
 8 larger doses made, by advancing the belt in a step-wise manner so that two or
 9 more printed "dots" or a printed line may be deposited at one site on the belt.
 10 The belt may then be advanced, and the process continued. Still other
 11 modifications are possible. For example, the invention advantageously may
 12 be used for "printing" diagnostic reagents or the like on a carrier or substrate.
 13 Still other modifications and variations of the invention described
 14 herein may be made and are intended to come within the scope of the
 15 appended claims.

CLAIMS

1
 2 1. In a dry powder inhaler comprising a first chamber in which a
 3 dry powder may be deaggregated by a vibrator and separated by size, and a
 4 second chamber in which the size-separated deaggregated powder may be
 5 picked up by an air stream and carried for introduction into a patient, the
 6 improvement which comprises electronic circuitry 48 for controlling dosing.
 7 2. In a dry powder inhaler according to claim 1, characterized by
 8 one or more of the following features:
 9 (a) wherein said microprocessor controller controls dosing
 10 according to a pre-determined delivery protocol;
 11 (b) wherein said electronic circuitry the quantity of powder
 12 delivered over time;
 13 (c) wherein the quantity of powder delivered over time is varied
 14 with time;
 15 (d) wherein said electronic circuitry counts doses delivered;
 16 (e) wherein said electronic circuitry monitors patient compliance,
 17 and optionally including means for recording patient usage, and for
 18 downloading the resulting record to a remote reader;
 19 (f) wherein said electronic circuitry includes a clock, and optionally
 20 including means associated with said clock for reminding a patient, wherein
 21 said means for reminding optionally comprises a tone generator;
 22 (g) wherein said electronic circuitry includes a clock and a lockout
 23 device associated with said clock for limiting frequency of use of said inhaler;
 24 (h) wherein said electronic circuitry further comprises a lockout
 25 device for preventing unauthorized use of said inhaler;
 26 (i) wherein said electronic circuitry further comprises an
 27 environmental sensor such as a temperature sensor associated with said
 28 electronic circuitry, for deactivating the inhaler in the event the inhaler is
 29 exposed to damaging environment;

1 (j) wherein said electronic circuitry further comprises a clock and
 2 lockout device for deactivating said inhaler at the expiration of a
 3 predetermined shelf life;
 4 (k) wherein said electronic circuitry is adapted to sweep said
 5 vibrators between two or more said frequencies;
 6 (l) wherein said electronic circuitry comprises a microprocessor;
 7 (m) wherein said electronic circuitry comprises a custom integrated
 8 circuit; and
 9 (n) wherein said electronic circuitry comprises discrete electrical
 10 and electronic components.
 11 3. In a dry powder inhaler comprising a first chamber in which a
 12 dry powder may be deaggregated by a vibrator and separated by size, and a
 13 second chamber in which the size-separated deaggregated powder may be
 14 picked up by an air stream and carried for introduction into a patient, the
 15 improvement which comprises two or more vibrators 90A, 90B designed to
 16 vibrate at different frequencies.
 17 4. A pressure sensor and controller for an inhalation device
 18 comprising: an acoustic controller, said acoustic controller including an
 19 acoustic element 208 being to sense fluid pressure around said element and
 20 for producing signals representative of a frequency and amplitude of said
 21 fluid pressure, said signals being used to control certain components 226, 228
 22 of said inhalation device.
 23 5. A sensor and controller as claimed in claim 4, characterized by
 24 one or more of the following features:
 25 (a) wherein said signals 244 control an activation/deactivation of a
 26 high frequency vibrator 228 to vibrate and deaggregate powdered
 27 medicament to induce said medicament into said fluid;

1 (b) wherein said signals 236 control an activation/deactivation of
 2 an electrostatic plate 226 to attract certain particles towards said electrostatic
 3 plate and into said fluid;
 4 (c) wherein said signals 248' control activation of a timer, said timer
 5 being to control said certain components of said inhalation device;
 6 (d) wherein said acoustic sensing element 208 is a microphone;
 7 (e) wherein said acoustic sensing element is a fluid pressure
 8 transducer;
 9 (f) wherein said inhalation device is a dry powdered medicament
 10 inhaler that includes an fluid passage 212 to permit air to enter the device
 11 upon inhalation, a dry powder medicament dispenser including a vibratory
 12 mechanism 228 to vibrate said powdered medicament into said air stream,
 13 said vibratory mechanism being controlled by said acoustic controller, and an
 14 electrostatic plate 226 to draw certain particles of said powdered medicament
 15 towards said electrostatic plate and into said air stream, said electrostatic
 16 plate being controlled by said acoustic controller;
 17 (g) wherein said acoustic controller further comprises an
 18 inspiratory capacity processor 238 to obtain data related to the flow rate
 19 around said sensor and to use said data to further control said certain
 20 components of said inhalation device, wherein said data preferably includes
 21 minimum and maximum fluid flow rate which is indicative of inspiratory
 22 and/or expiratory effort of a user of said inhalation device; and
 23 (h) wherein said acoustic element 208 is positioned within said
 24 inhalation device to obtain optimal fluid around said sensor.
 25 6. An inhalation device comprising: an fluid passage 212; an
 26 acoustic controller including an acoustic element 208 positioned within said
 27 fluid passage and being to sense fluid around said element and for producing
 28 signals representative of a frequency and amplitude of said fluid; a high
 29 frequency vibrator 228 to vibrate and deaggregate powdered medicament to

35

1 adjustments to the amount of charge and/or the area is made to attract the
 2 predetermined desired amount of powder to said "image" area;
 3 (d) wherein a high velocity air stream is used to deaggregate and
 4 aerosolize the powder particles and a holding chamber is used to control the
 5 particle size distribution in the air stream using particle settling times;
 6 (e) wherein the charge "image" is produced by an ion beam whose
 7 intensity and/or area can be varied;
 8 (f) wherein the charge "image" is produced by a photon beam
 9 whose intensity and/or area can be varied;
 10 (g) wherein means are provided for controlling particle size
 11 distribution of particles in the powder deposited on the charge "image";
 12 (h) wherein said powder carrying surface and said transport belt
 13 are synchronized to move together; and
 14 (i) wherein said partially formed package comprises an edible
 15 wafer.
 16 10. The method of packaging dry powder pharmaceuticals, drugs and
 17 reagents comprising the steps of developing a predetermined electrostatic
 18 charge having a predetermined "image" area on a powder carrier surface,
 19 contacting said carrier surface with a sufficient amount of powder to
 20 neutralize said charge, whereby to isolate a predetermined quantity of
 21 powder, moving said isolated quantity of powder and said surface to a
 22 transfer station, transferring said isolated quantity of powder to a transport
 23 belt, and dividing said belt to form discrete packages each containing a
 24 predetermined amount of powder.
 25 11. A method according to claim 10, characterized by one or more
 26 of the following features:
 27 (a) wherein said transport belt comprises an edible material;
 28 (b) wherein said powder carrier surface comprises a separate
 29 element carried on said belt, and including the step of stripping said separate

37

1 induce said medicament into said fluid, said high frequency vibrator being
 2 controlled by said signals 224; and an electrostatic plate 226 to attract certain
 3 particles of said powdered medicament towards said electrostatic plate and
 4 into said fluid, said electrostatic plate being controlled by said signals 236.
 5 7. A pressure sensor and controller comprising: an acoustic
 6 controller, said acoustic controller including an acoustic element 208 to sense
 7 turbulence around said element and for producing signals representative of a
 8 frequency and amplitude of said fluid pressure.
 9 8. The method of packaging dry powder pharmaceuticals, drugs
 10 and reagents comprising the steps of developing a predetermined
 11 electrostatic charge having a predetermined "image" area on a powder carrier
 12 surface, contacting said carrier surface with a sufficient amount of powder to
 13 neutralize said charge, whereby to isolate a predetermined quantity of
 14 powder, moving said isolated quantity of powder and said surface to a
 15 transfer station, transferring said isolated quantity of powder to a partially
 16 formed discrete package carried on a transport belt, whereby to form a
 17 discrete packaging containing said predetermined amount of powder.
 18 9. A method according to claim 8, characterized by one or more of
 19 the following features:
 20 (a) wherein said partially formed package comprises an open-
 21 ended capsule, including the step of sealing said capsule by capping;
 22 (b) wherein said partially formed package comprises a partially
 23 formed tablet, and including the step of completing formation of said tablet
 24 after transferring said powder thereto;
 25 (c) wherein said predetermined charge and area on said carrier
 26 surface are estimated, said estimated electrostatically charged area is then
 27 exposed to said powder of opposite charge and the amount of powder
 28 attracted to said predetermined area is measured, thereafter necessary

36

1 element from said transport belt, and wherein the separate material
 2 optionally comprises an edible material preferably starch;
 3 (c) wherein said predetermined charge and area on said carrier
 4 surface are estimated, said estimated electrostatically charged area is then
 5 exposed to said powder of opposite charge and the amount of powder
 6 attracted to said predetermined area is measured, thereafter necessary
 7 adjustments to the amount of charge and/or the area is made to attract the
 8 predetermined desired amount of powder to said "image" area;
 9 (d) wherein a high velocity air stream is used to deaggregate and
 10 aerosolize the powder particles and a holding chamber is used to control the
 11 particle size distribution in the air stream using particle settling times;
 12 (e) wherein the charge "image" is produced by an ion beam whose
 13 intensity and/or area can be varied;
 14 (f) wherein the charge "image" is produced by a photon beam
 15 whose intensity and/or area can be varied;
 16 (g) wherein means are provided for controlling particle size
 17 distribution of particles in the powder deposited on the charge "image";
 18 (h) wherein said powder carrying surface and said transport belt
 19 are synchronized to move together; and
 20 (i) wherein said transport belt comprises an edible material;
 21 preferably starch.
 22 12. Apparatus for packaging for powder comprising:
 23 a source of powder 316,
 24 a powder carrier surface 324;
 25 means 325 for applying a predetermined electrostatic charge to a
 26 predetermined area of said carrier surface, to create a charge "image" 325A on
 27 said surface,
 28 means 320 for applying to said powder an electrostatic charge opposite
 29 to that of said electrostatic charge on said carrier surface;

38

1 means 326 for exposing said charged area of said area on said carrier
 2 surface to charged powder to create a powder "image" on said carrier surface,
 3 means 330 for transferring said powder adhering to said carrier surface
 4 to a transfer system and neutralizing said electrostatic charge on said carrier
 5 surface to cause the powder to transfer into a discrete, package 329, carried on
 6 a transport belt 328.

7 13. The apparatus according to claim 12, characterized by one or more
 8 of the following features:

9 (a) wherein said package comprises a partially formed package 329,
 10 and including means 332 for sealing said discrete, partially formed package;

11 (b) wherein the means 325 for placing the electrostatic "image" on
 12 the carrier surface is adjustable both in intensity and area so that the exact
 13 amount of electrostatic charge and area thereof can be controlled;

14 (c) which additionally includes a means 318A to control the powder
 15 particle size distribution to ensure repeatability and accuracy of powder
 16 metering;

17 (d) wherein a high frequency vibrator such as a piezo crystal,
 18 electromagnetic, mechanical or other means is used to deaggregate the
 19 powder 316B and an electrostatic potential 324 is used to aerosolize the
 20 particle size distribution of interest;

21 (e) wherein the charge "image" 325A is produced by an ion beam
 22 352 whose intensity and/or area can be varied;

23 (f) wherein the charge "image" 325A is produced by a photon beam
 24 whose intensity and/or area can be varied;

25 (g) wherein said partially formed package comprises open capsules
 26 329, and wherein said means for sealing said partially formed package
 27 comprises a capsule sealing station 332;

1 (h) wherein said partially formed package comprises partially
 2 formed tablets 360, and said means for sealing said partially formed tablet
 3 comprise means 366 for finish forming said tablets;

4 (i) and including means for indexing movement of said powder
 5 carrier surface and said transport belt, and optionally including means 330 for
 6 activating said transfer system to neutralize said electrostatic charge when
 7 said transport belt and said carrier surface are in predetermined position
 8 relative to one another; and

9 (j) wherein said powder is transferred onto an edible sheet 388
 10 carried on the transport belt 382, and including means for dividing said edible
 11 sheet into discrete packages 390.

12

13

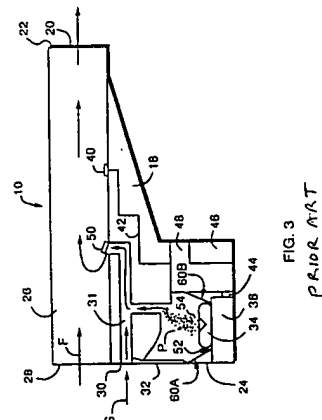
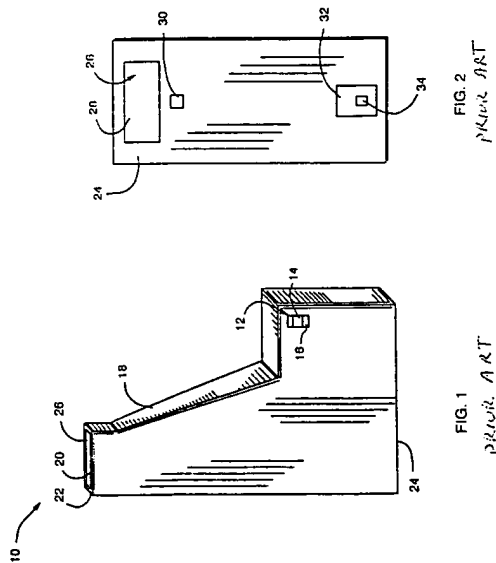

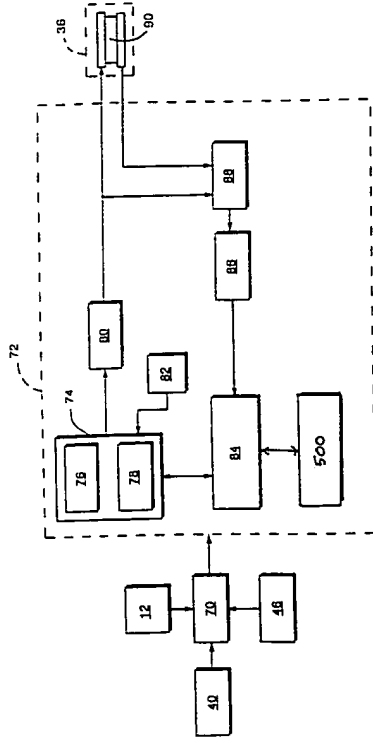

FIG. 4

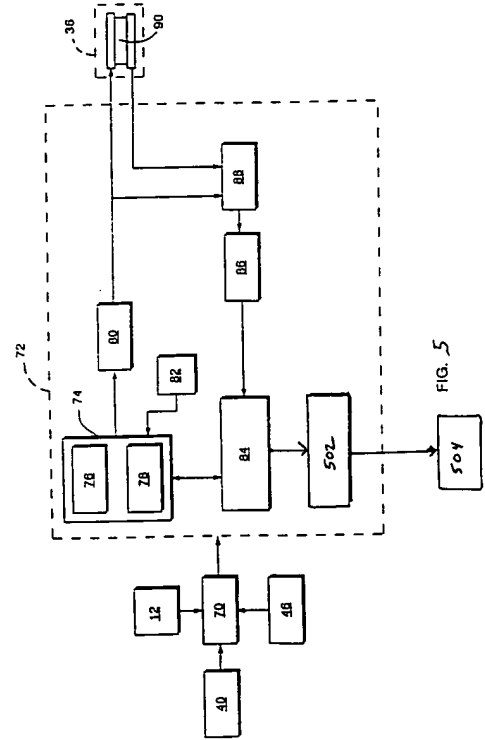

FIG. 5

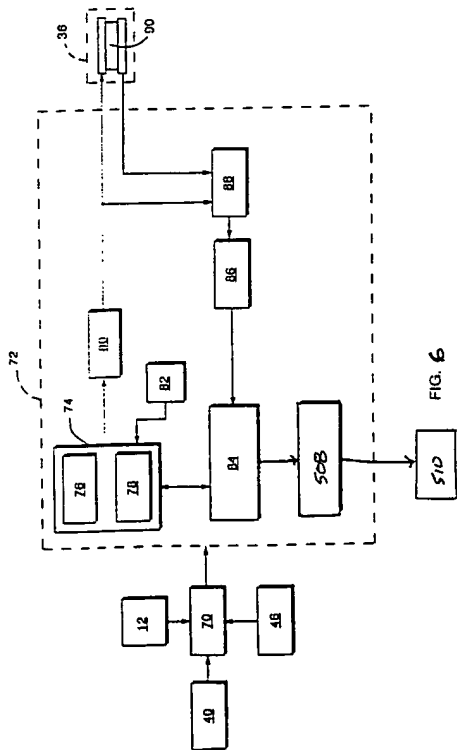

FIG. 6

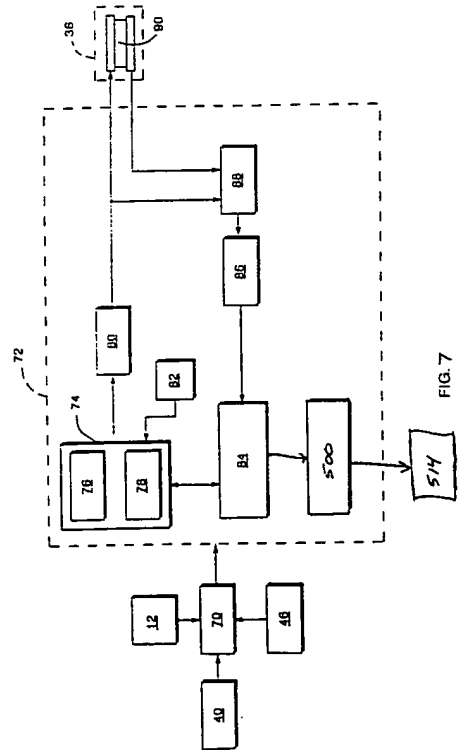

FIG. 7

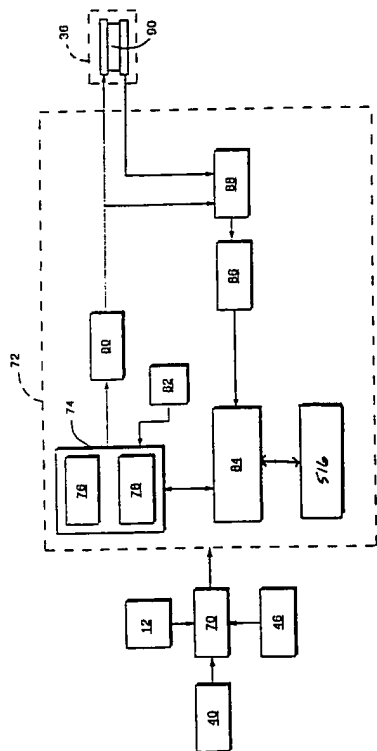

FIG. 8

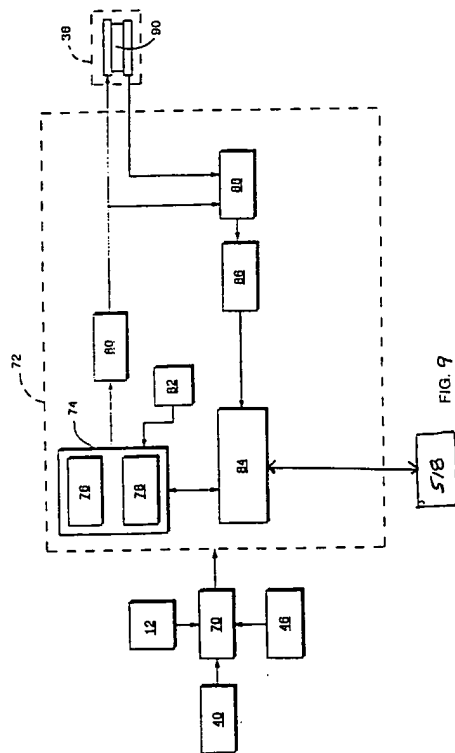

FIG. 9

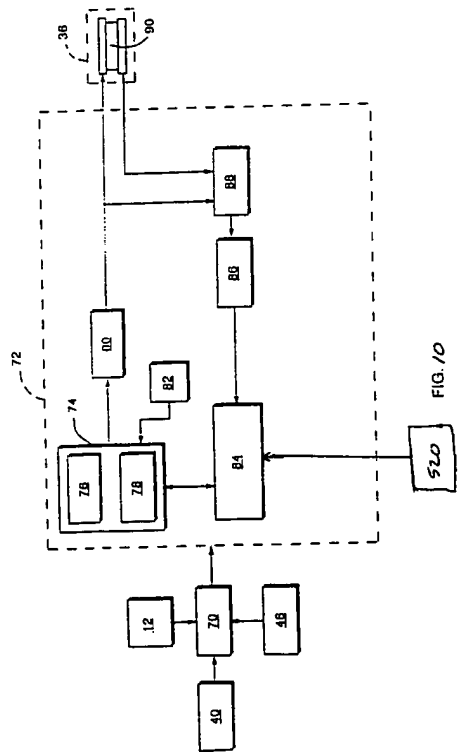

FIG. 10

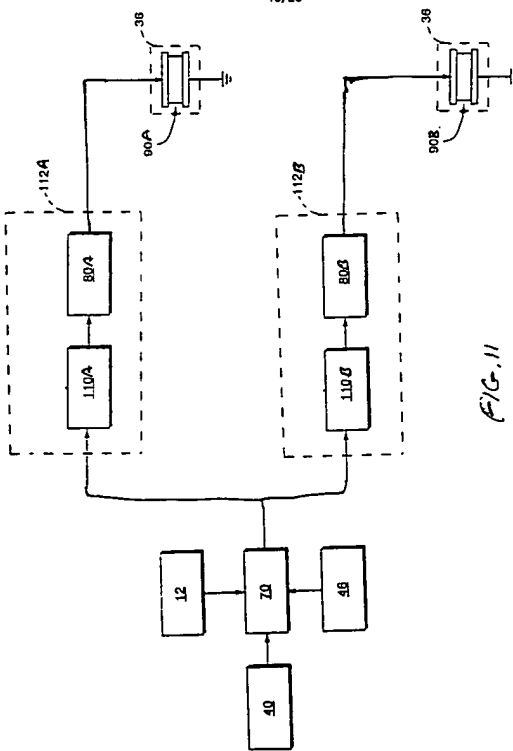

FIG. 11

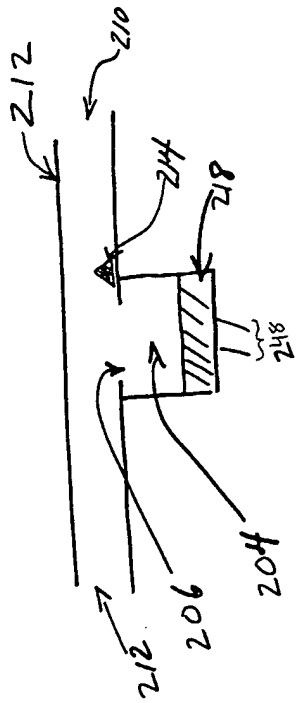

Fig 12

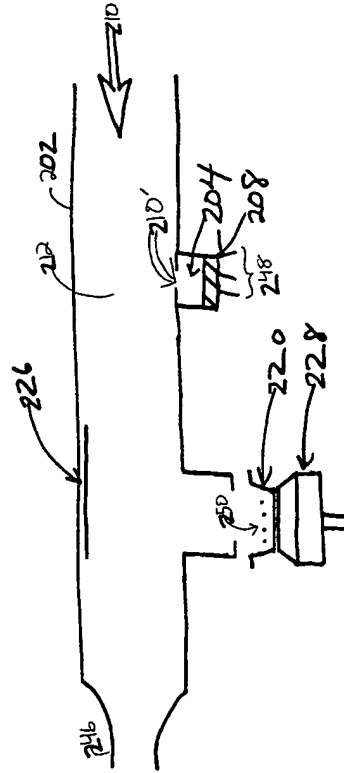

Fig 13

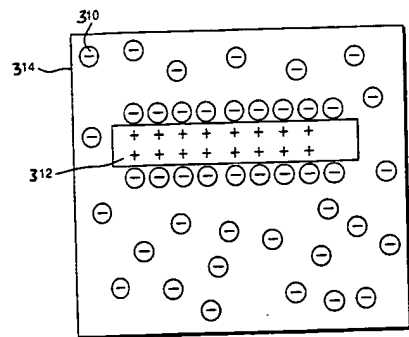

FIG. 15
PRIOR ART

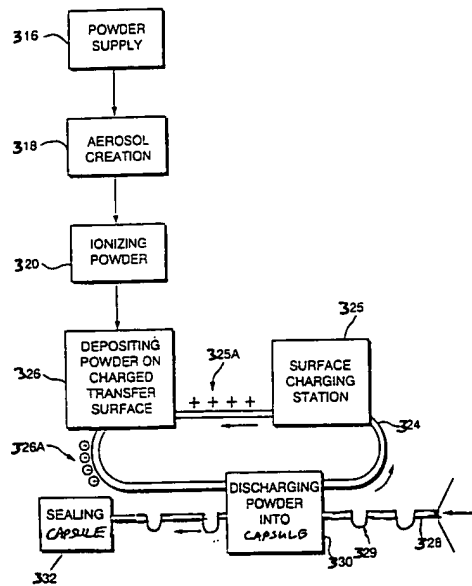

FIG. 16

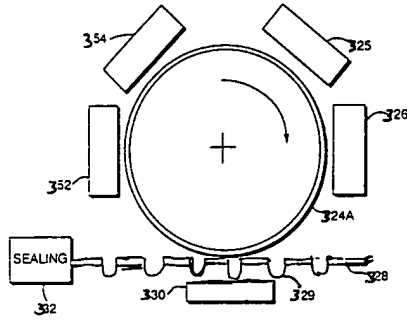

FIG. 17

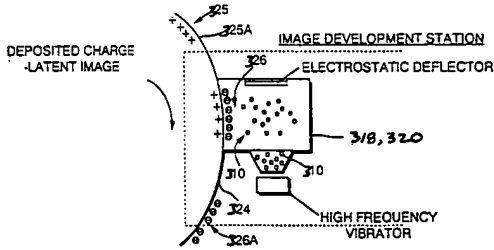

FIG. 18
PRIOR ART

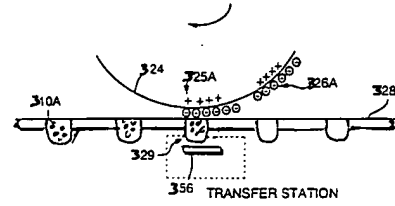

FIG. 19

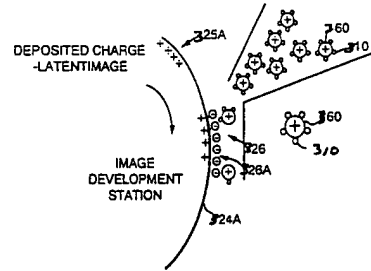

FIG. 20
PRIOR ART

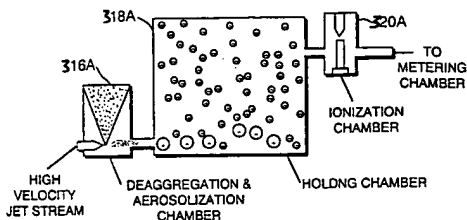

FIG. 21
PRIOR ART

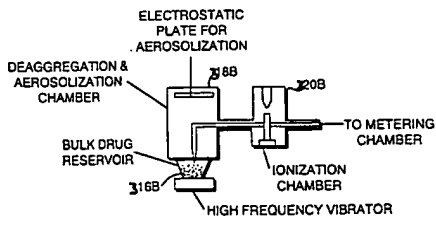

FIG. 22
PRIOR ART

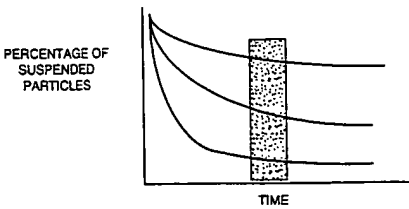

FIG. 23- PRIOR ART

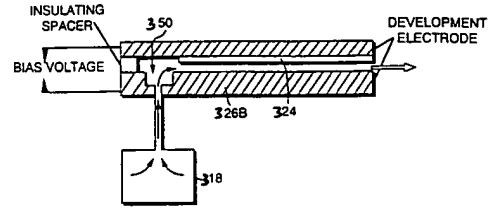

FIG. 24
PRIOR ART

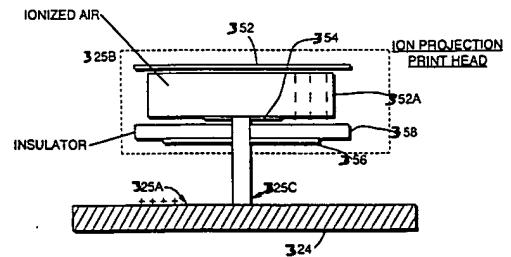

FIG. 25
PRIOR ART

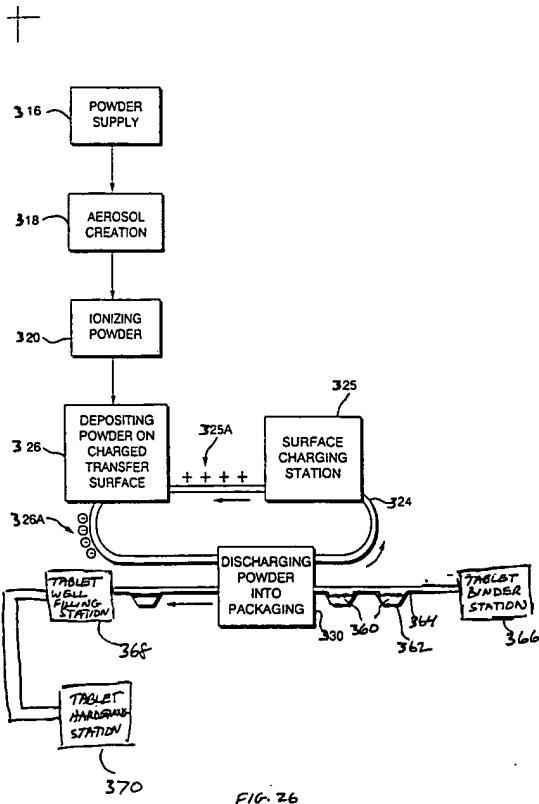

FIG. 26

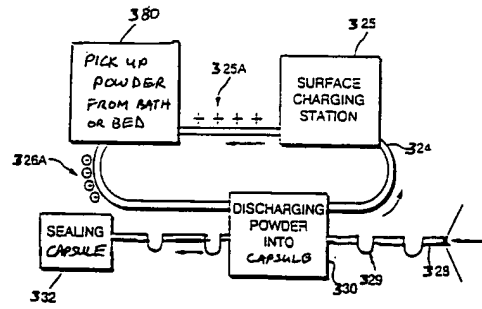

FIG. 27

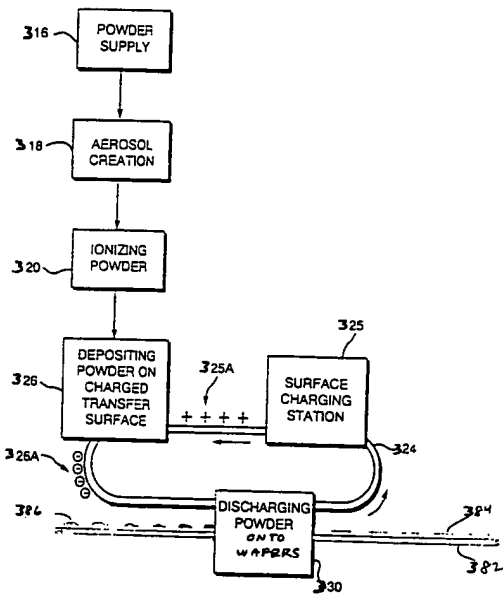

FIG. 28

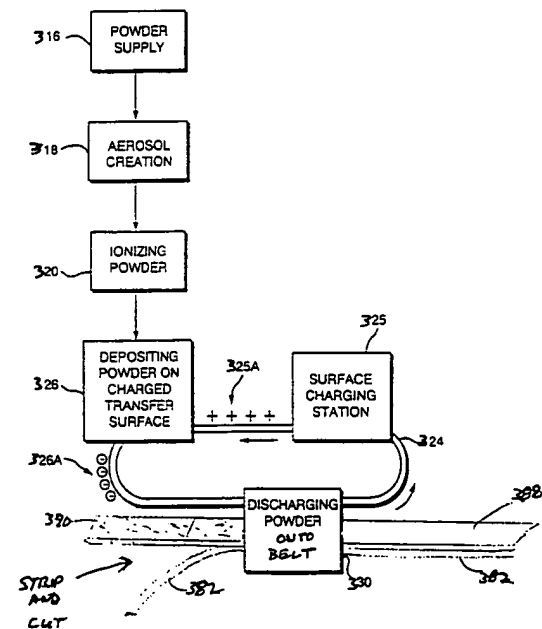

FIG. 29

FIG. 14

